

Use 2.5mm hex wrench and 5.5mm socket drive for this step.

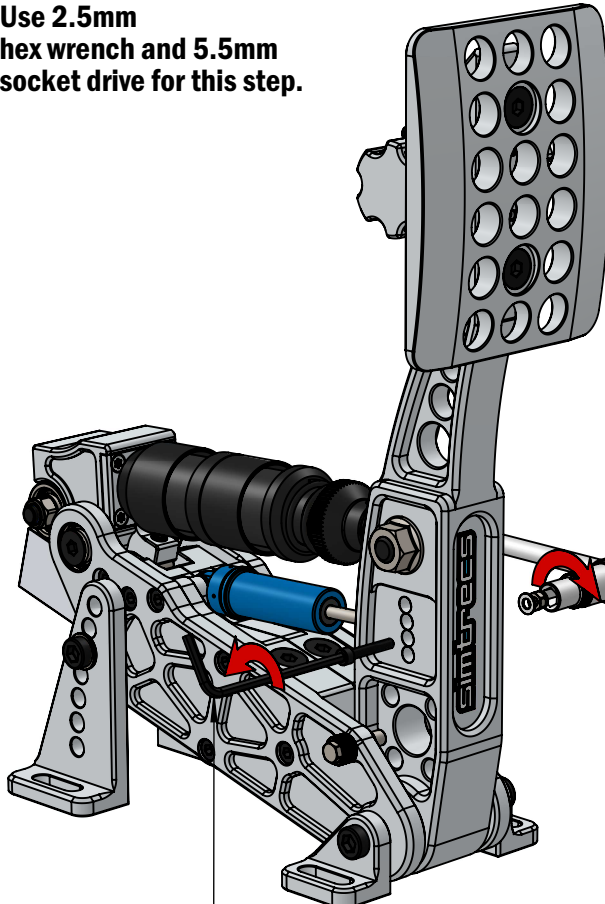

STEP 1
REMOVE THE SCREW
AND THE NUT

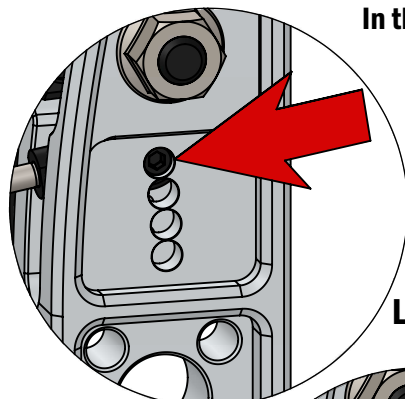

HIGHER DAMPING RESISTANCE

In the highest position, pedal has a higher damping resistances, whilst in the lowest position pedal has lower damping resistances.

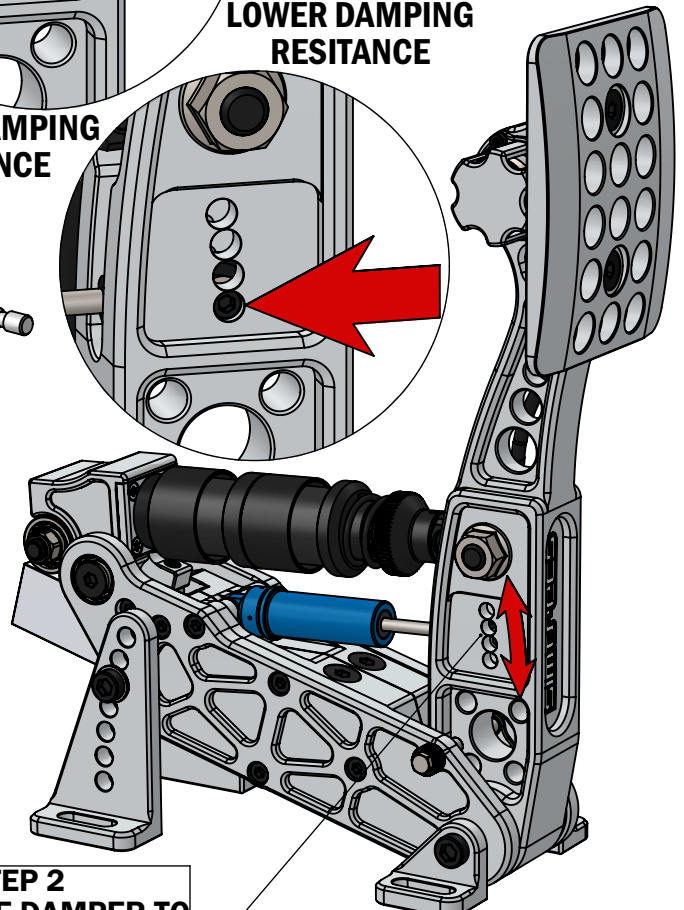

LOWER DAMPING RESISTANCE

STEP 2
ADJUST THE DAMPER TO
THE DESIRED POSITION.

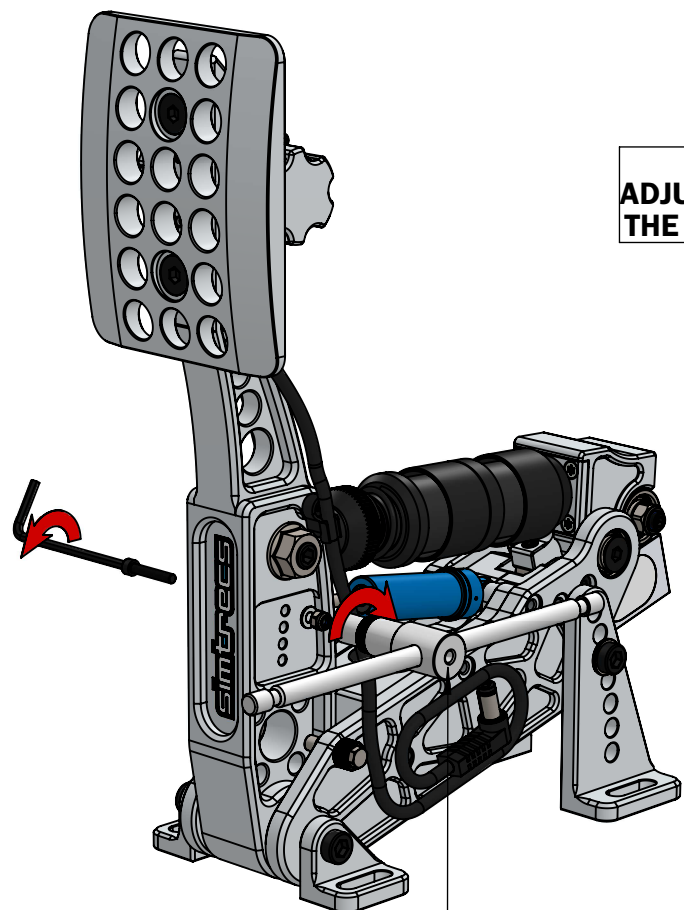

STEP 3
RE-ATTACH AND
TIGHTEN THE
SCREW AND THE NUT

Use 2.5mm hex wrench for this step.

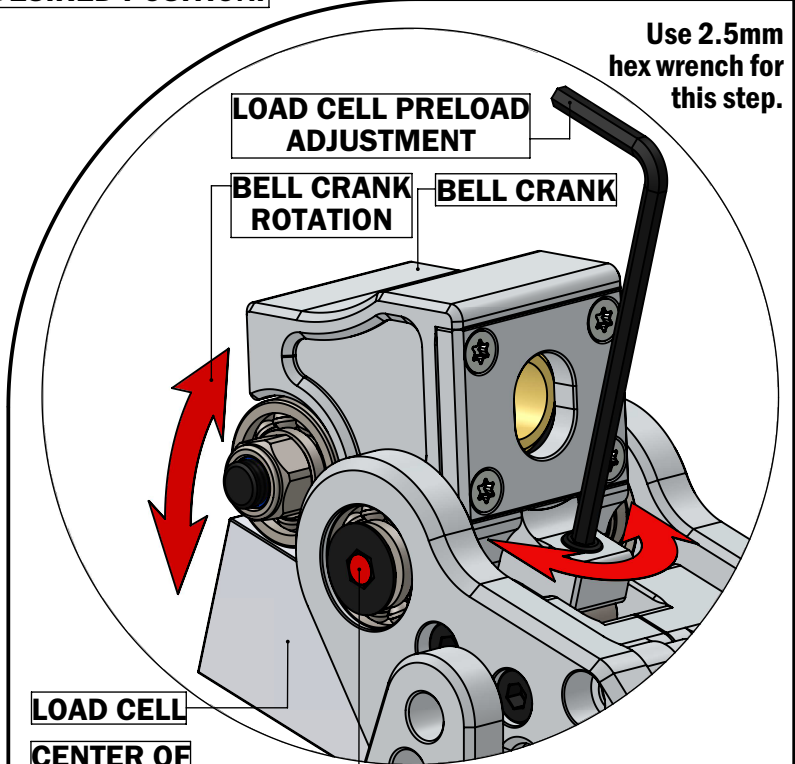

LOAD CELL PRELOAD ADJUSTMENT

BELL CRANK ROTATION

BELL CRANK

LOAD CELL

CENTER OF ROTATION

During use if there is a gap between the load cell and the bell crank bearing, please adjust its preload with a screw.