

STEP 1
LOOSEN THE
SCREW.

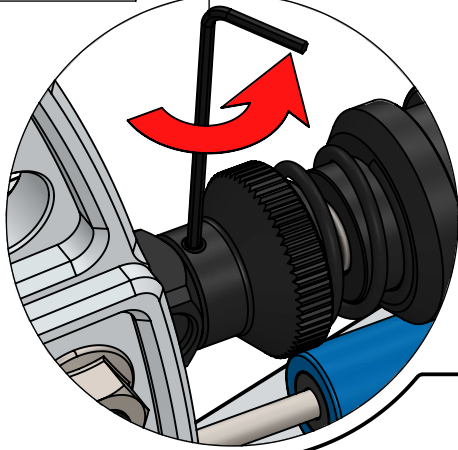

STEP 2
TURN THE ADJUSTER NUT TO
THE DESIRED POSITION.

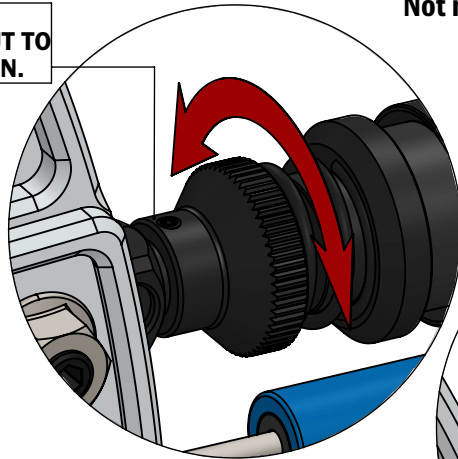

Not necessary to use the securing screw.
Use 1.5mm hex wrench
for this step.

STEP 3
GENTLY TIGHTEN
THE SCREW.

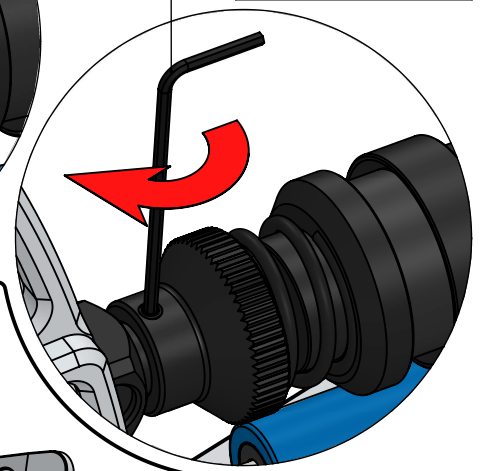

Use 3mm hex wrench
for this step

STEP 1
REMOVE THE SCREW.

IF THE SCREW IS
BLOCKED BY THIS
BRACKET, THEN
REMOVE THEM FIRST.

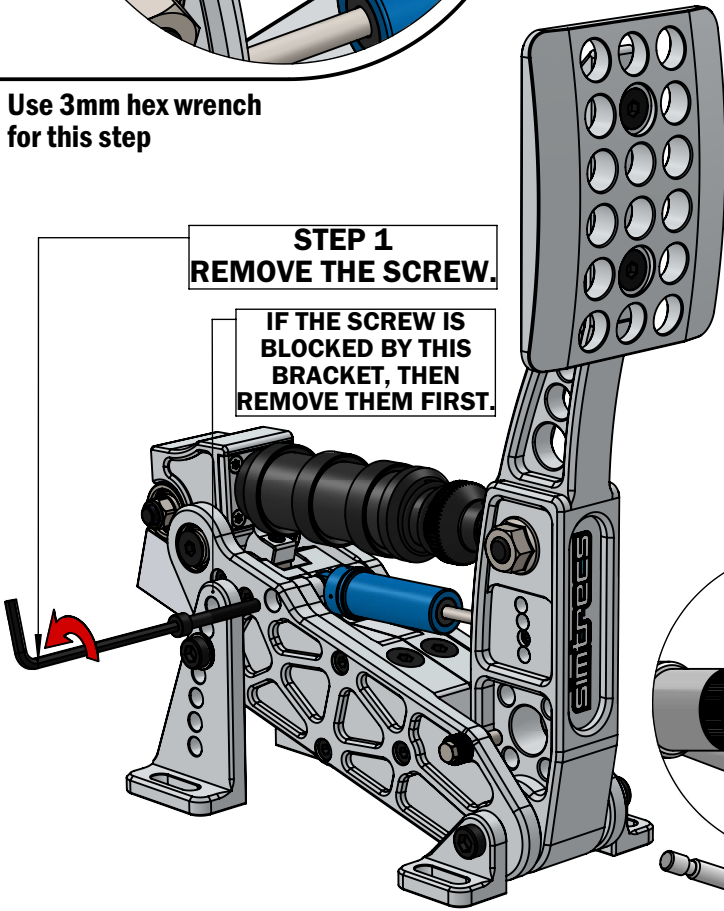

STEP 2
REMOVE THE 2 SIDE
SCREW WHILE YOU
PUSH THE PEDAL
A LITTLE BIT
BACKWARDS.

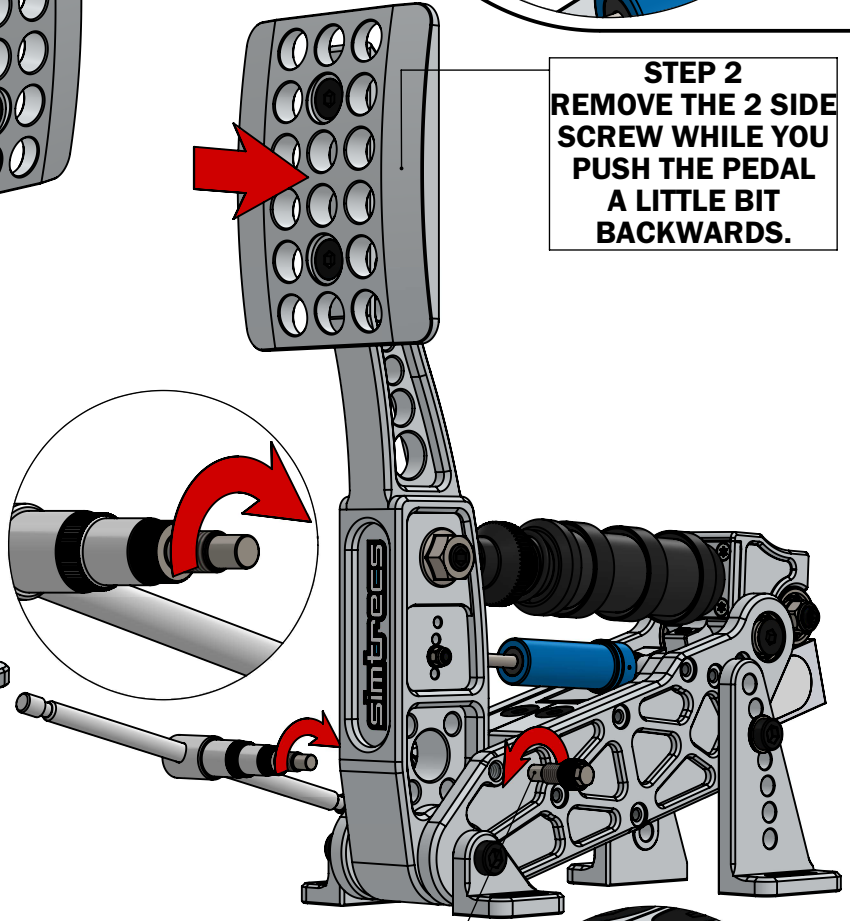

USE 6mm SOCKET DRIVE TO
OPEN THESE SCREWS IF
THEY ARE TO TIGHT.

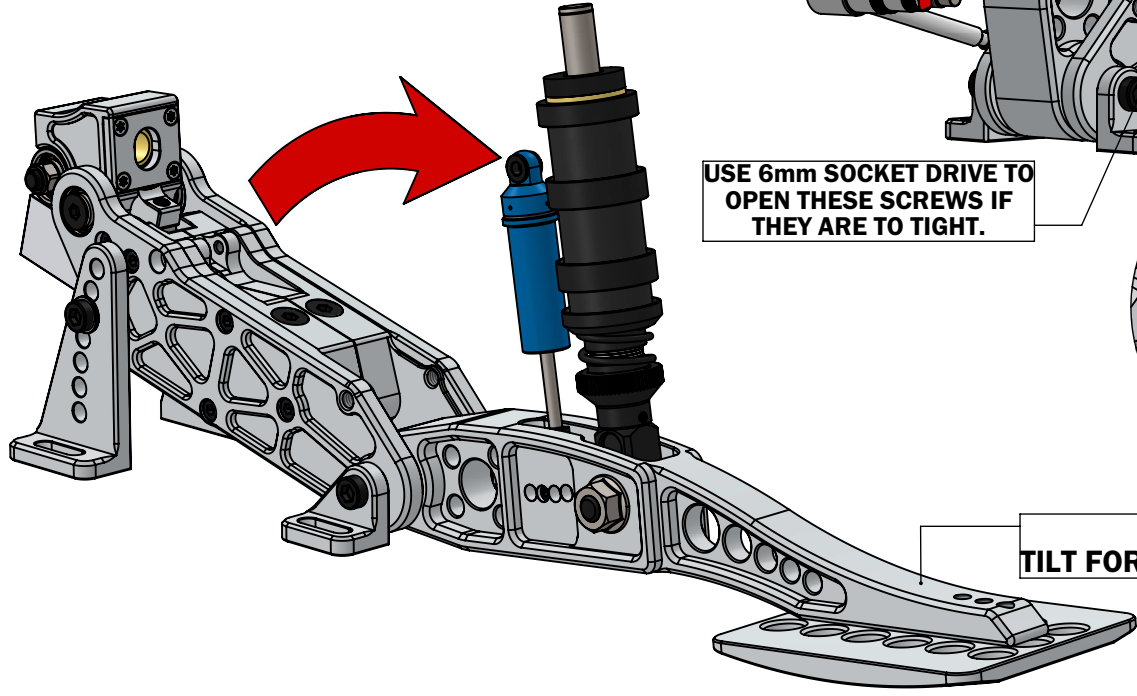

STEP 3
TILT FORWARD THE PEDAL ARM.