

The brake system has two stages. The first stage simulates the real brake system pad-to-disk gap with a spring, the second stage simulates the flex of brake calipers and brake lines.

The gap can be set by two ways.

- 1: Reduce or increase the gap by the adjuster nut. Please note, this method gives preload of the spring too.
- 2: By adding spacers between the adjuster nut and the first disk of the elastomer pack.

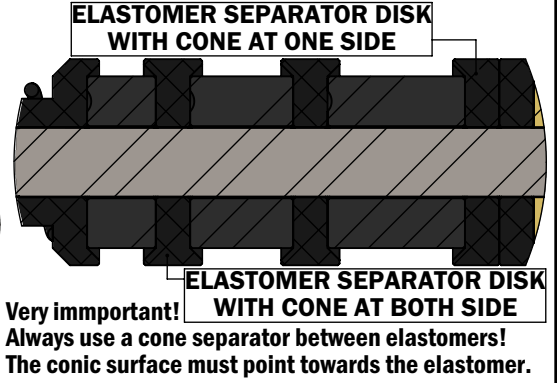
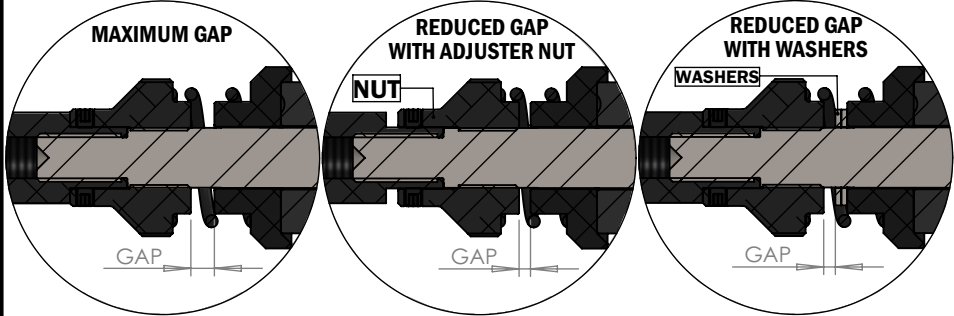
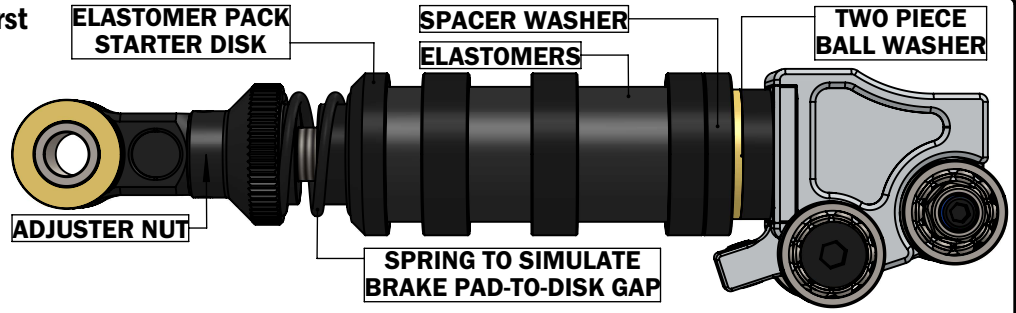

Pedal elastomer layout combinations.
Elastomer hardness need to be selected.

