

The load cell on the brake pedal is a very sensible sensor. Industrial Direct Drive motors, on steering or in motion systems in specific situations could cause EMI on the brake pedal signal. The sign of an EMI is random vibration or spikes on the pedal output. If pedal is mounted on a metal baseplate probably there will be no EMI. In spite of this, if there is still an EMI, the solution is to connect the supplied ground wire to the pedal.

Please note grounding wire is included only for maximum safety. If there is no EMI issue then grounding wire is unnecessary!

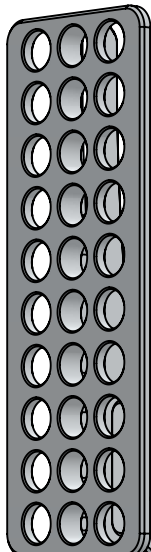

The brake pedal force can be adjusted "on the fly" with a potentiometer.

E.g.:

Potentiometer set close to minimum setting:
50kg pressure on the pedal = 95% brake force in the simulator software

Potentiometer set close to maximum setting:
100kg pressure on the pedal = 95% brake force in the simulator software

BRAKE PEDAL FORCE ADJUSTER POTENTIOMETER

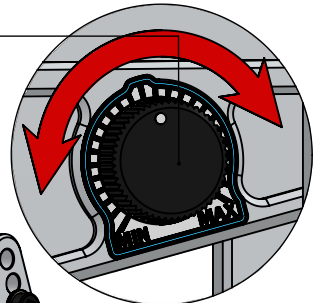

FOLLOW THE PLUG IDENTIFICATION TEXT ON THE PEDAL BASE.

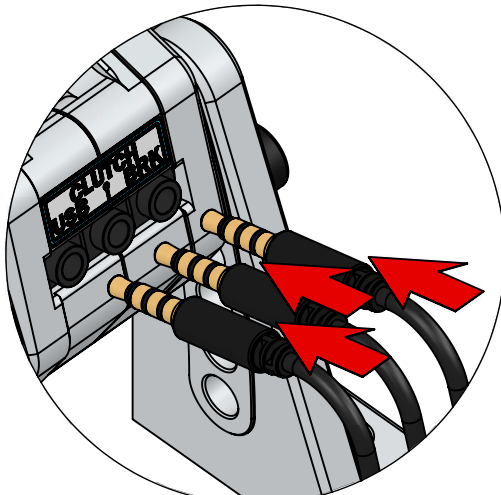
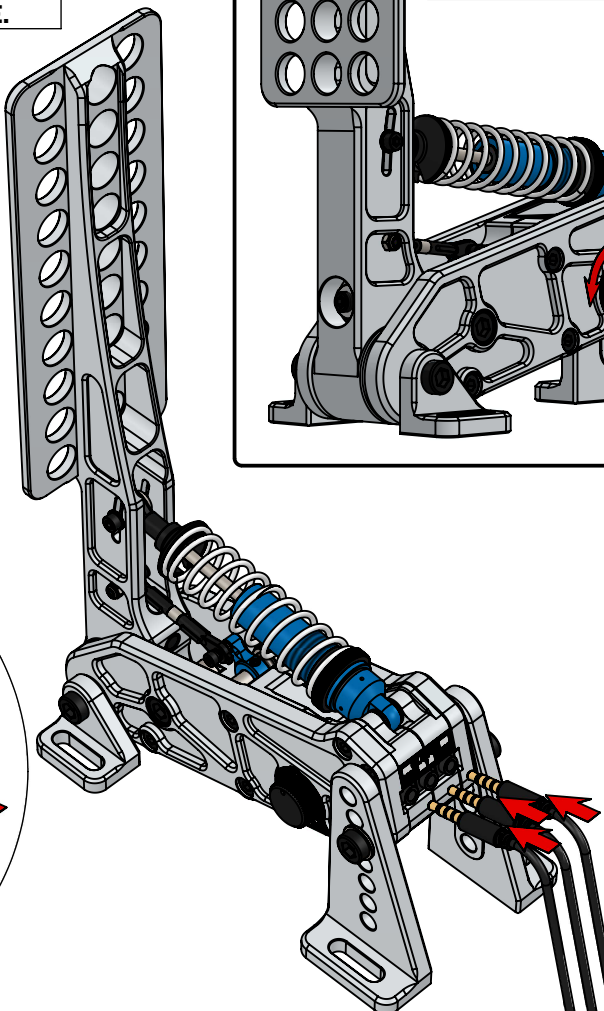
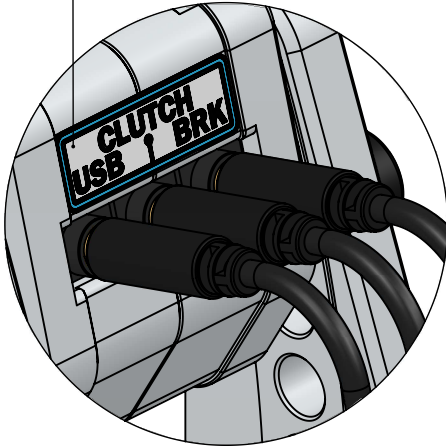

SIMULATOR COMPUTER

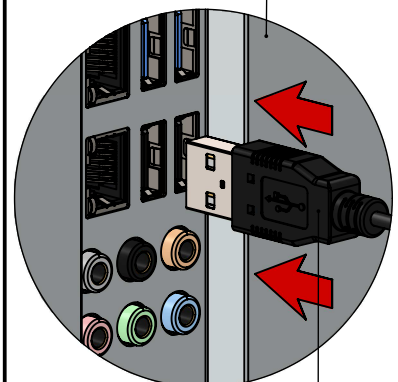

PEDAL USB CABLE