

**THROTTLE UNIT**

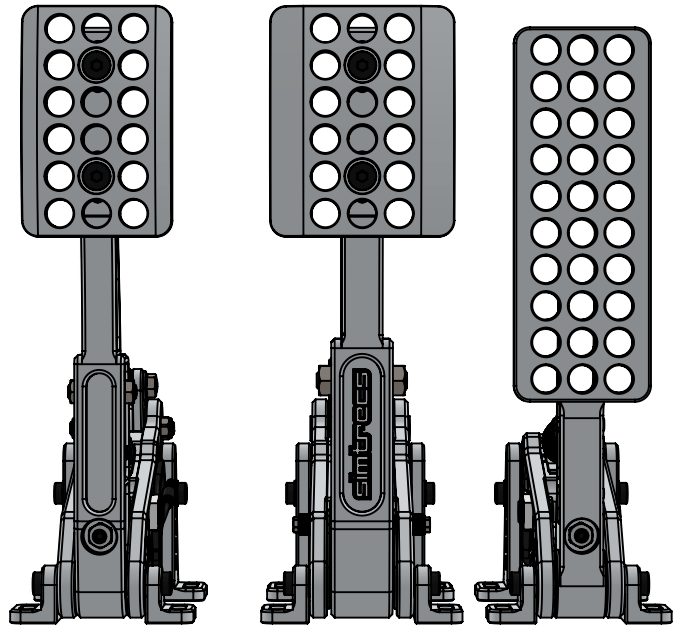

**MODULAR DESIGN**  
**INDEPENDENTLY ADJUSTABLE PEDAL POSITIONS**

**CLUTCH UNIT**

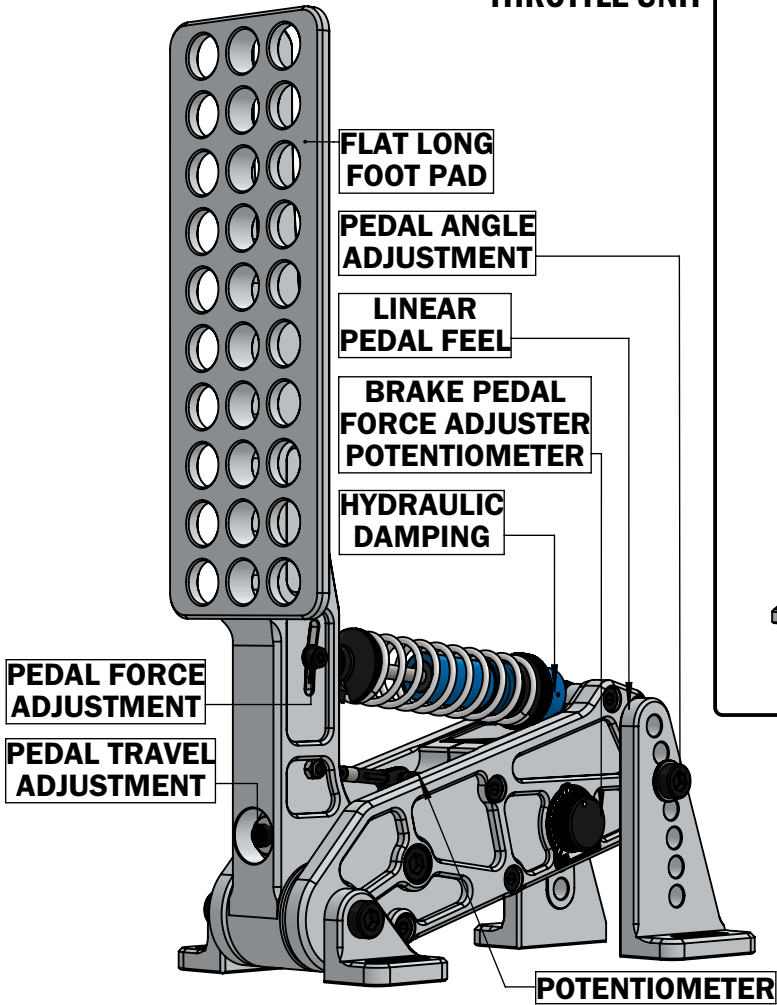